

Corporate Headquarters
 2631 Highway J
 Bourbon, MO 65441
 Phone (573) 732-3318
 Fax (573) 732-9408



Engineering & Manufacturing
 2631 Highway J
 Bourbon, MO 65441
 Phone (573) 732-3318
 Fax (573) 732-9408

SOLUTIONS FOR EXTENDING EXCHANGER LIFE

HYDRAULIC EXPANSION DATA SHEET

DATE	CONTACT	PHONE
HYDRAULIC EXPANSION END USER		JOB #

SCOPE OF APPLICATION AND SPECIFICATIONS

NEW OR RETUBE	NUMBER OF EXPANSIONS	APPROXIMATE START DATE
TYPE OF UNIT:		
<input type="radio"/> Heat Exchanger	<input type="radio"/> Boiler	
<input type="radio"/> Condenser	<input type="radio"/> Other (Describe):	
<input type="radio"/> Feedwater Heater		

TUBES

QTY TUBES	MATERIAL	ACTUAL YIELD	ACTUAL TENSILE
O.D.	WALL THICKNESS/GAGE	WALL (CIRCLE ONE): <i>Avg. / Min. / Nominal</i>	
ACTUAL TUBE I.D. MEASUREMENT			TYPE: <i>Seamless / Welded Drawn</i>
U-BEND OR STRAIGHT		OVERALL LENGTH OF TUBE	
SETTING OF TUBE TO TUBESHEET PRIMARY FACE: <i>Recessed / Flush / Protruding</i>			
MAX. PROTRUSION OF TUBE ON SECONDARY TUBESHEET			
ARE THE TUBES TO BE WELDED TO THE TUBESHEET: <i>Yes / No</i>		HAVE TUBES BEEN PROPERLY ANNEALED: <i>Yes / No</i>	

TUBESHEET

TOTAL THICKNESS	MATERIAL	ACTUAL YIELD	ACTUAL TENSILE
CLAD: <i>Yes / No</i>	THICKNESS	MATERIAL	
SHELL ATTACHED: <i>Yes / No</i>	PARTITION PLATE: <i>Yes / No</i>		
IF "YES" TO EITHER OF THE ABOVE: SHORTEST DISTANCE BETWEEN HOLE CENTER LINE AND SHELL/PLATE			

HOLES

DIAMETER	CHAMFER: <i>Yes / No</i>	WHERE IS THE CHAMFER LOCATED: <i>Face / Back</i>
DEGREE OF CHAMFER		DEPTH OF THE CHAMFER

GROOVES

NUMBER	Note: as a minimum, placement of the 1 st groove should begin 1/2" from the face of the tubesheet or in the center based on tubesheet thickness.	
TEMA: <i>Yes / No</i>	IF "NO", PLEASE PROVIDE SPECIFICATIONS IN THE AREA PROVIDED ON PAGE 2.	
CUSTOMER RECEPTIVE TO HYDRAULIC EXPANSION GROOVE: <i>Yes / No</i>	Note: hydraulic expansion groove is a single wide groove (centered in sheet if possible).	

LIGAMENT

THICKNESS	PITCH	HOLE PATTERN
-----------	-------	--------------

HYDRAULIC EXPANSION DATA SHEET (CON'T)

EXPANSION ZONE

START OF EXPANSION INSIDE TUBESHEET
STOP OF EXPANSION DISTANCE FROM REAR OF TUBESHEET
TOTAL EXPANSION ZONE

TUBE-TO-TUBESHEET WELD REQUIREMENTS

ARE TUBES TO BE WELDED: <i>Yes / No</i>	IF "YES": <i>Seal Welded / Strength Welded</i>
WILL YOU TUBE LOCK PRIOR TO WELD: <i>Yes / No</i>	
WHAT IS THE MAXIMUM COUNTER SINK O.D. FOR WELD	

EXPANDING PRESSURE REQUIREMENTS

CONTACT ONLY: <i>Yes / No</i>	HYDROTEST PRESSURE	APPROXIMATE START DATE
NOTE: WHEN WELDING, THE FOLLOWING EXPANSION PROCEDURE IS RECOMMENDED.		
1. <i>TubePro; setting of tube</i>	3. <i>Hydraulic Expand</i>	
2. <i>Weld</i>	Note: <i>No weld rollover is recommended when hydraulic expanding</i>	

SPECIFICATIONS (IF APPLICABLE)

Please provide any available drawings, sketches, or blueprints, as well as performance requirements regarding working and test pressure of the vessel.

Drawings Supplied: *Yes / No*

EXTERNAL EXTENSIONS

For expansion which require going around an interference such as a channel, shell, partition plate, or any other obstruction, creating a situation where expansion would take place at a distance from the tubesheet face.

DISTANCE FROM OUTSIDE FACE OF SHELL OR PLATE TO FACE OF TUBESHEET
IS THERE ACCESS FOR A STOP COLLAR TO BE LOCATED AT TUBESHEET FACE OR OUTSIDE OF SHELL: <i>Yes / No</i>

INTERNAL EXTENSIONS

For expansions which require mandrel travel within a tube, re: inner tubesheet of a dual tubesheet application, baffle expansions, or expansion of a tubesheet through the opposite end.

DISTANCE FROM TUBESHEET FACE TO FACE OF INNER TUBESHEET OR BAFFLE.
--

Signature: _____ Date: _____

DATA SHEET SUPPLEMENT

The Data Sheet Supplement form is provided as an aid and can be useful when gathering information for filling out the data sheet. Only the completed Data Sheet must be sent in.

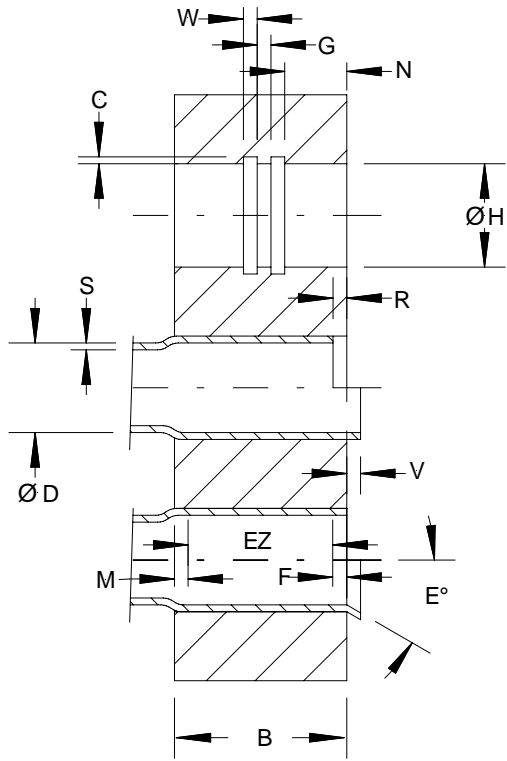

 Tube o.d. (D) _____
 Tube wall thickness (S) _____
 Tube material _____

 Tube Hole Diameter (H) _____
 Tube Sheet Thickness (B) _____
 Tube sheet mat'l _____

 Quantity Grooves _____
 Groove width (W) _____
 Groove depth (C) _____
 Gap between grooves(G) _____
 Distance to 1st groove (N) _____

 Expansion zone (EZ) _____
 E.Z. front setback (F) _____
 E. Z. rear setback (M) _____
 Tube protrusion(V) _____
 Tube recess (R) _____
 Bell/Flare angle ° (E) _____

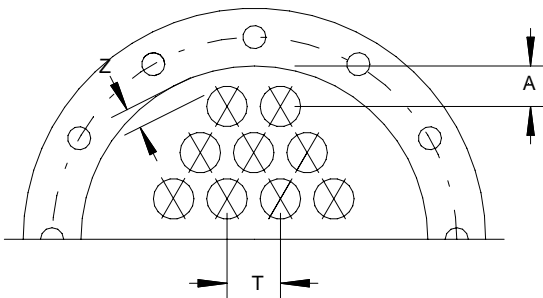

 Hole center -to-center (T) _____
 Center-to-shell (A) _____
 Hole o.d. \-to-shell (Z) _____

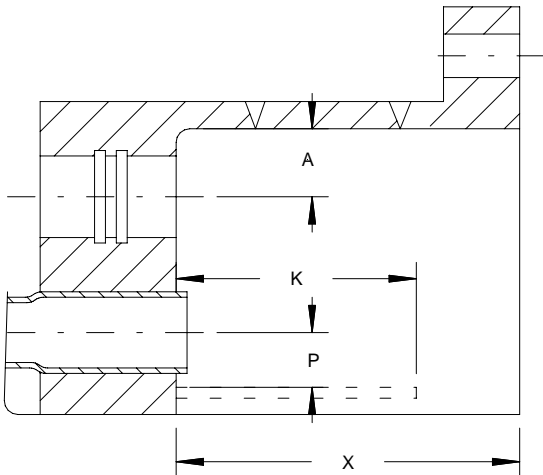

 Center-to-shell (A)
 (same as above)
 Division plate height (K) _____
 Hole Center to div. plate (P) _____
 Depth of channel (X) _____